

DJ8510

► *Higher Flexibility In The Corrugated Board Printing*



Print on demand

Digital printing allows you to print the quantity you want in very short time to change the print template.

Higher flexibility, increase your range of product

Available for the carton factory accept slast minute orders and thus increases flexibility to cope with customer urgently demands. Short and medium runs can now become cost-effective runs.

Save time, save labor, save cost

Digital printing allows no plate printing. This will save the fixed cost of production while saving time to wait for the plate to start production. There is no ink wasting like traditional machines.

**High-Resolution
Inkjet Printer**

FEATURE

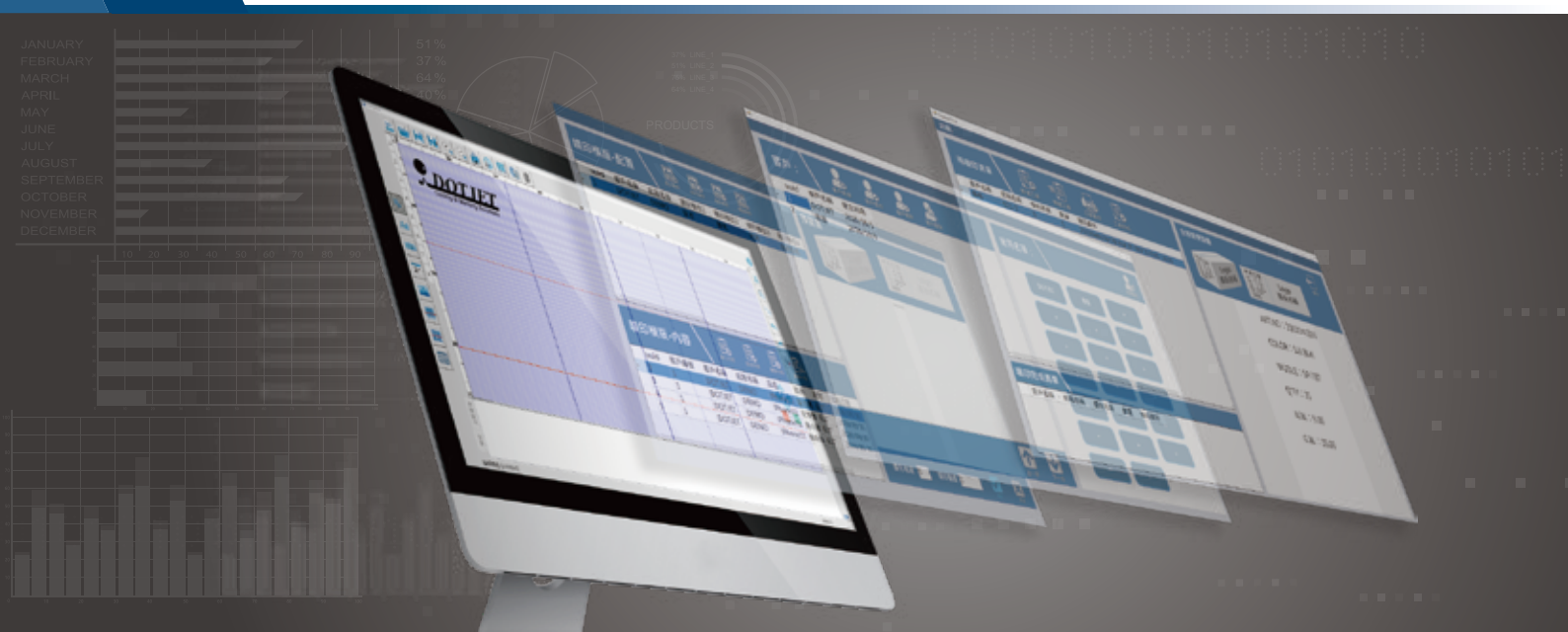

Controller and Software

The DJ4510/8510 controller is based on the PC / Windows operating system embedding DotW_MD software. The DotW_MD combines a print template designer and a print job management software. WYSIWYG user-friendly with free design capabilities provides even a beginner can quickly and efficiently build-up a print template. All the print jobs and templates are classified by customer names letting the operator quickly get any of them to print.

The DotW_MD will automatically generate a unique code giving every print jobs at it is done in design, the code can print on the corrugated board along with the template, let your next time printing can quickly search the print job by the code as well.



2 levels password protection/
user and administrator.

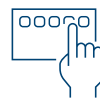

Remote edit print template and
message via PC with the VNC
software installed.



Database oriented can quickly
build a new print job under an
existing print template.



A smartphone can monitor printer
remotely, the production line
operation status will show up
transparently no matter at anywhere.

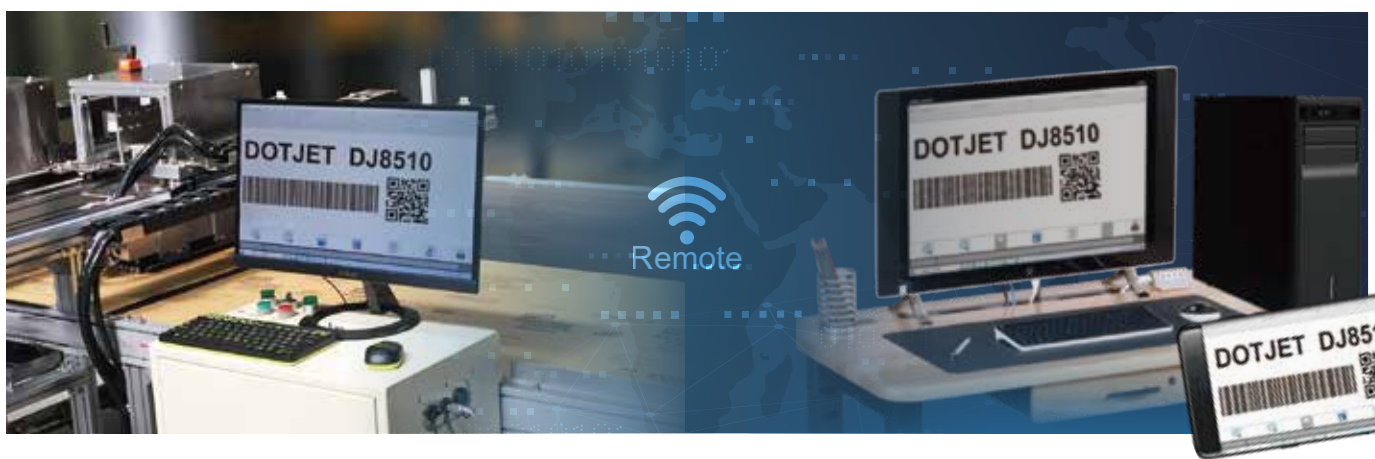

FEATURE



Two type of print heads, the 4510 print head consists of four 72mm print engine stitched to reach 29cm. The 8510 print head is 2 independent 4510 heads combination into a 58cm height print.

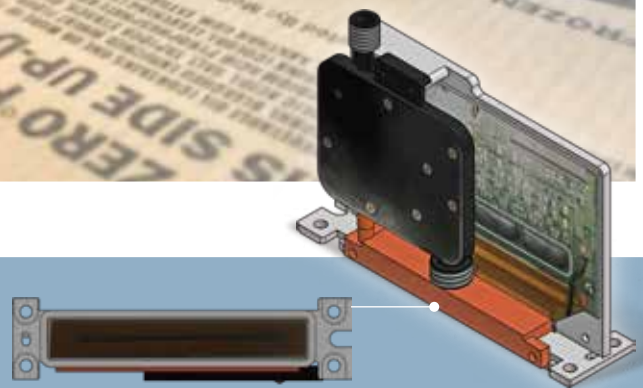
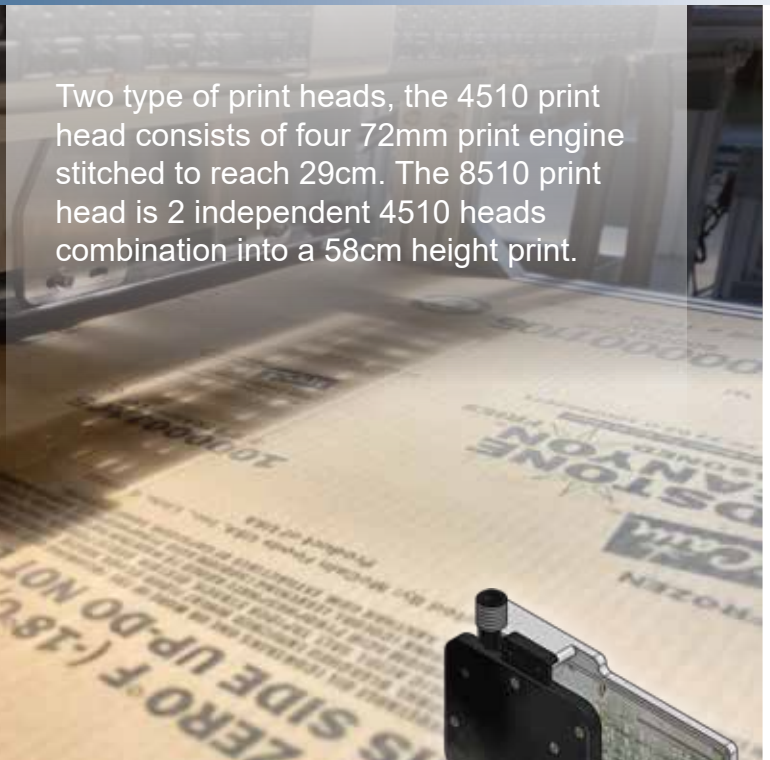

Native horizontal resolution of 180dpi gives a sharply print at the speed to 148 ft/min.

The print head is allowing to use oil, solvent and UV inks. For running UV ink fluently in a low temperature environment, a heating facility has built-in to maintain the print head interior in a certain temperature.

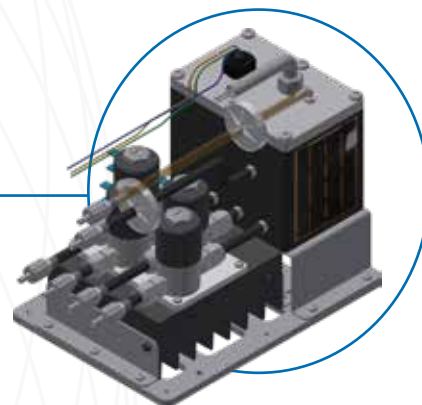

A secondary ink tank built-in accessorize a negative air pressure pump to keep ink with consistent pressure to supply to the print head for the best print quality.

Ink Delivery System

The ink delivery system can constantly and stably act for supplying ink to the print head and controlling the functions related to ink working. Negative air pressure is generated for keeping the print head ink tank with constant air pressure after the system power ON, it could let ink supply to the print head smoothly to achieve the best print quality and completely get rid of the problem of ink dripping from nozzle. Once the system acts for ink priming, ink drain, and ink purging, positive air pressure will quickly be turned to implement the functions. On the software operation panel, all the ink functions can easy to be controlled by clicking.



1 liter ink capacity supplying to each 4510 print head



Air pressure is allowed to set up to get the best condition for output a stable air pressures into the print head, that is one of the points to implement the best print quality.

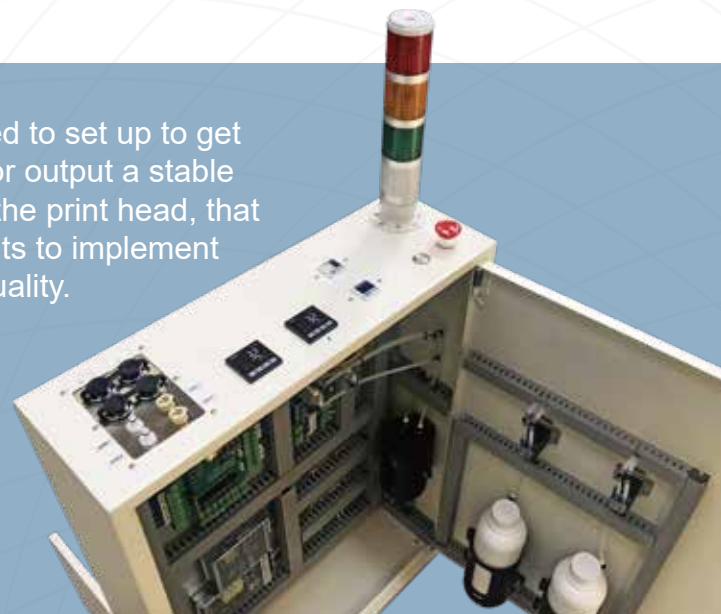

Conveyor System

Maximum line speed at 50m/min

DJ4510 / 8510 is an inkjet printer system of the particular design for printing on corrugated board. A revolution for the corrugated carton industry, the inkjet printing system controller embeds DotW_MD operation software provides quickly print template creation and the content edit, saving time and space from the traditional rubber roller coder making and stock. DJ4510 / DJ8510 adopts piezoelectric technology to give a sharp print at resolution 180dpi. The system not only provides the function of print template creation but also assists to manage the massive print message file. Users can easily classify print jobs and quickly search any of them to print.

DJ4510 / DJ8510 is capable of using Oil and UV curing ink for printing on a regular corrugated board with a porous surface and the non-porous glossy cardboard surface. The inks are water assistant and perfect for long-term storage in the warehouse.



Print head elevation facility with figure meter for height adjustment reference.



Ruler assists quickly move the print head modules to corrected position.

Mechanism and Conveyor

Dotjet is a specialist of high-resolution inkjet printer, capable of designing complete inkjet printer including control unit with operation / management software, print head driver board, ink delivery system, accessories and cooperate with excellent ink manufacturer provides the best solution in inkjet printing.

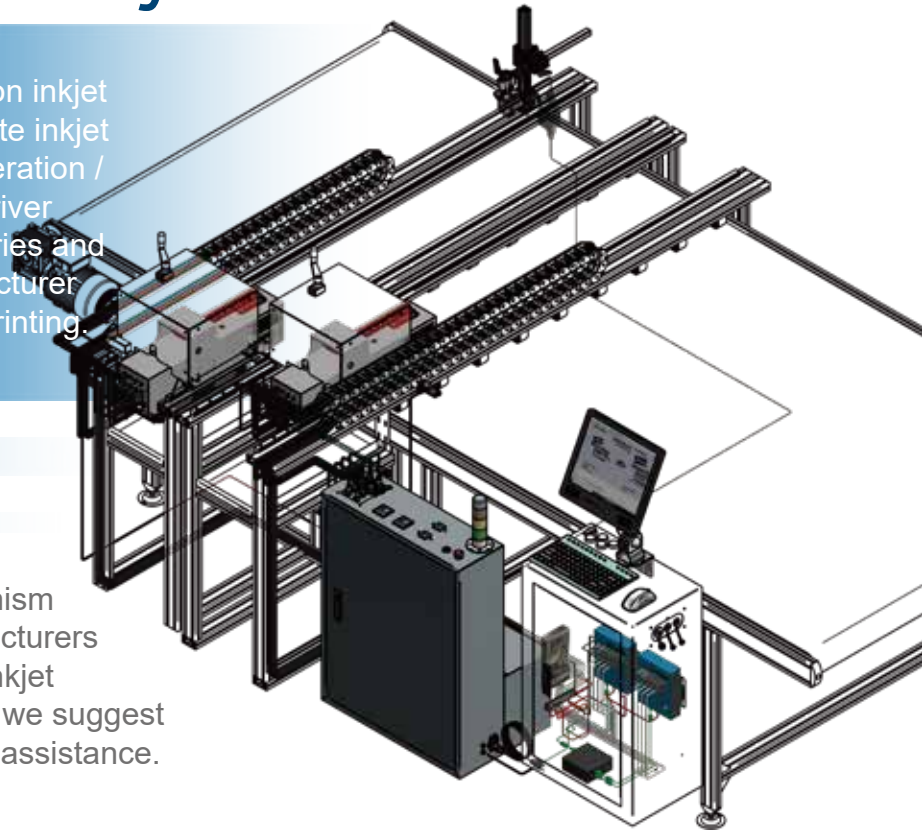

The conveyor system with the mechanism is designed and made by other manufacturers that can well integrate with the Dotjet inkjet system. For cost-saving consideration, we suggest the system can be made locally by our assistance.

DJ8510 inkjet system consist of

Print head module

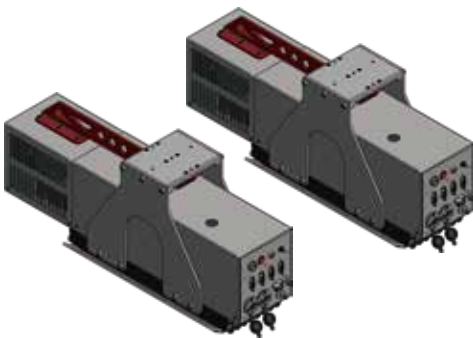

Print driver board



Data lines



LVDS lines



Control board



Ink tubes



Air tubes



Ink delivery system



Encoder



Power supply



Photo-sensor



USB lines



SPECIFICATION

Technology	Seiko Piezoelectric Technology
Power supply	AC110-220V, 50/60HZ
Controller and display	Controller : PC base, Windows operating system Monitor : Customer-made
Operating temperature range	5°C ~45°C (41°F - 113°F)
Message storage	Unlimited
Built-in message storage capacity	4GB SDD available for message storage, actual message size will vary based on content
Print head	Stitching with four 510BN print engines - 4510 head Stitching with eight 510BN print engines - 8510 head
Maximum print height	290mm - 4510 head 580mm - 8510 head
Print range	Maximum 58cm x 200cm
Print resolution	180 dpi
Printing orientation	Vertical printing
Distance to print Surface	Maximum 6.5mm (0.25 inches)
Print speed	148 ft/min (45m/minute) at 180dpi - Standard print 72 ft/min (22.5m/minute) at 180dpi - Darken print
Print Software	Alphanumeric of full true type fonts. Scalable text; rotation, mirror and inverse printing. Graphic format supported using 1 bit bitmap file. (*.bmp) GS1 barcodes / 2D codes. Remote monitor and control ability. Print message and file management.
Database print format	CSV
External data communication interface	RS232, USB, Ethernet, TCP/IP
Max. distance controller to print head	5m
Particular features	MySQL database, Print data collection
Ink usage	Oil and UV curing inks
Ink supply	1 liter bottle ink feeds to per 4510 print head
Dimension (L/W/H)	Print head 61 x 13.5 x 19 (cm) / 24 x 5.3 x 7.4 (inches) Ink delivery system 62.5 x 41 x 114 (cm) / 24.6 x 16.1 x 44.8 (inches)
Optional	Encoder, bulk ink supply, External low ink alarm



Dotjet Inc.

 www.dotjet.com

 info@dotjet.com

 +886 4 2338 7066

 No.10 Gaotie 2nd Rd., Wuri Dist., Taichung City, 414012 Taiwan